

POWER AMPLIFIER

KAC-648/S

SERVICE MANUAL

KENWOOD

© 1999-3 PRINTED IN KOREA
B51-7455-00 (K) 3272

KAC-648 (E)(M)

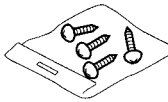

SCREW SET
(N99-1587-05)

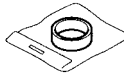

TERMINAL COVER SET
(W01-0748-05)



LEAD TERMINAL SET
(W01-0798-05)
(E type only)

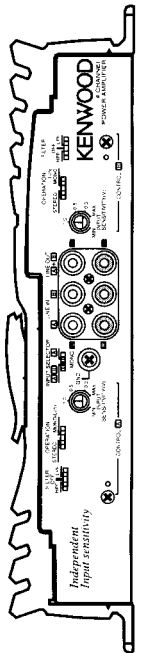
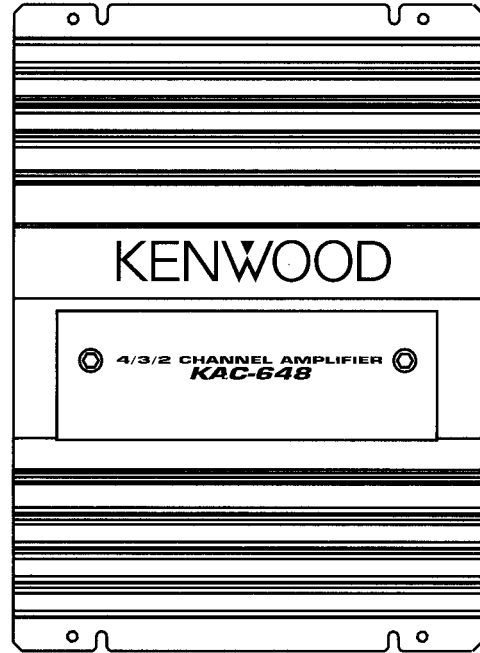
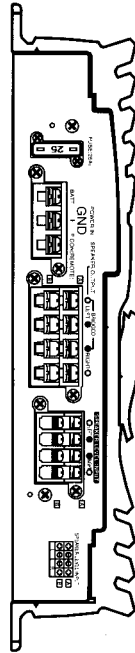

KAC-648S (K)

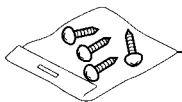

SCREW SET
(N99-1587-05)



TERMINAL COVER SET
(W01-0748-05)

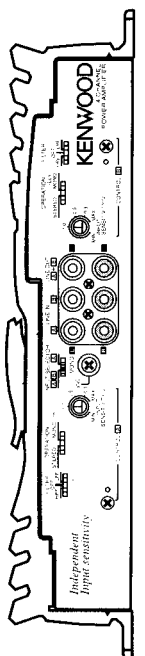
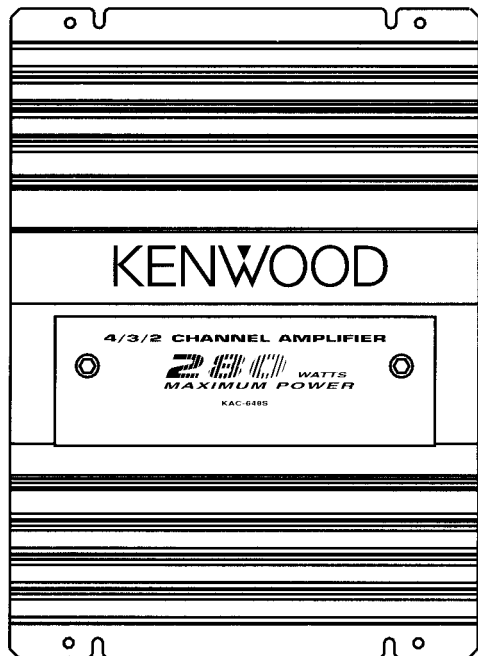
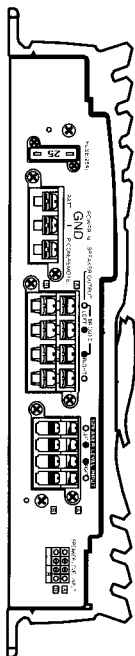

KAC-648/S

ADJUSTMENT

No.	ITEM	INPUT SETTINGS	OUTPUT SETTINGS	RECEIVER SETTINGS	ALIGNMENT POINTS	ALIGN FOR	FIG.
Connect a cassette receiver or CD receiver.							
1	IDEL CURRENT	-	Connect a DC voltmeter between CN1/CN2 and J3 (SP.OUT, L+/R-)	VOLUME : 0	(A) VR3 (L ch) VR4 (R ch) (B) VR5 (L ch) VR6 (R ch) (X09-)	5.5mV	(a)

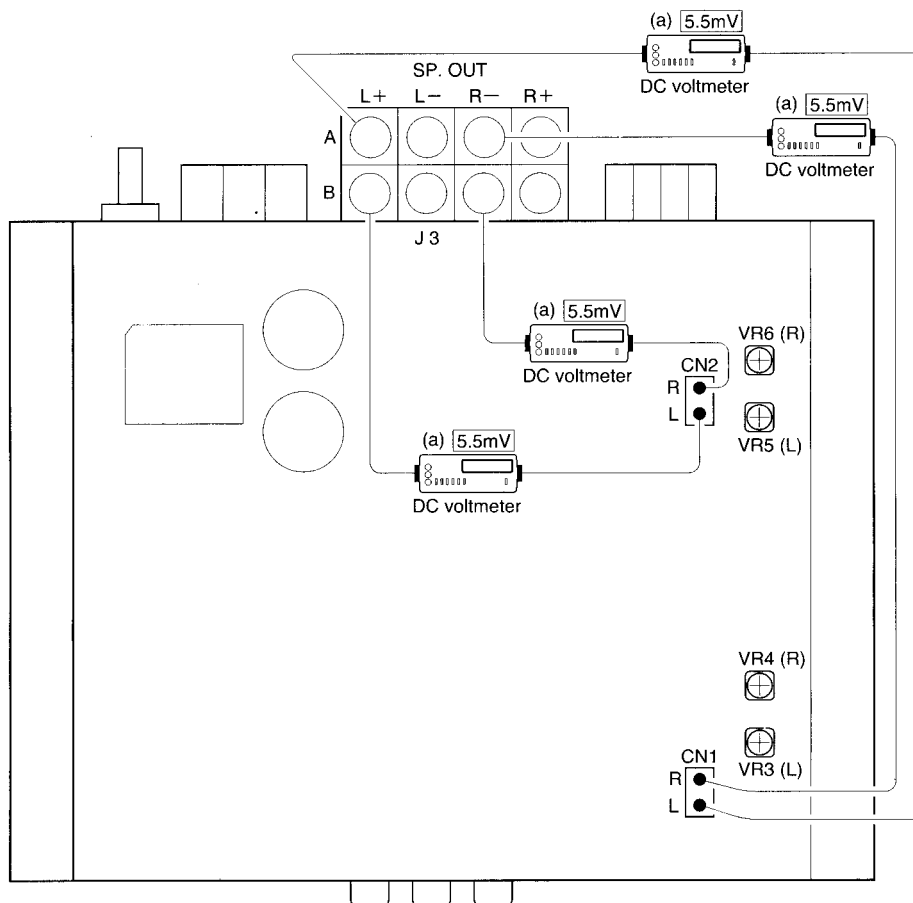

KAC-648/S (EM/K)

PC BOARD (Component side view)

1
2
3
4
5
6
7

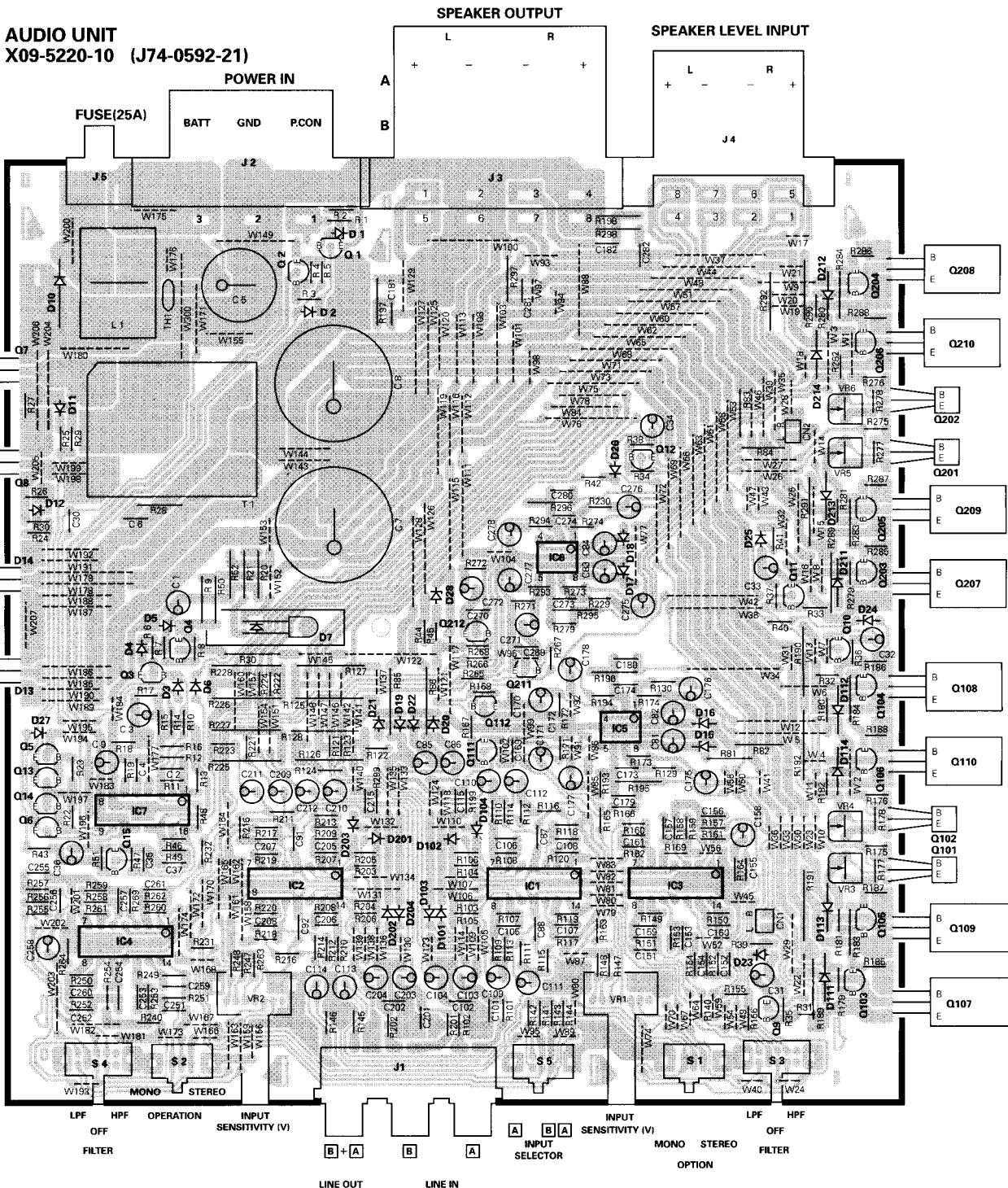

Refer to the schematic diagram for the value of resistors and capacitors.

PC BOARD (Foil side view)

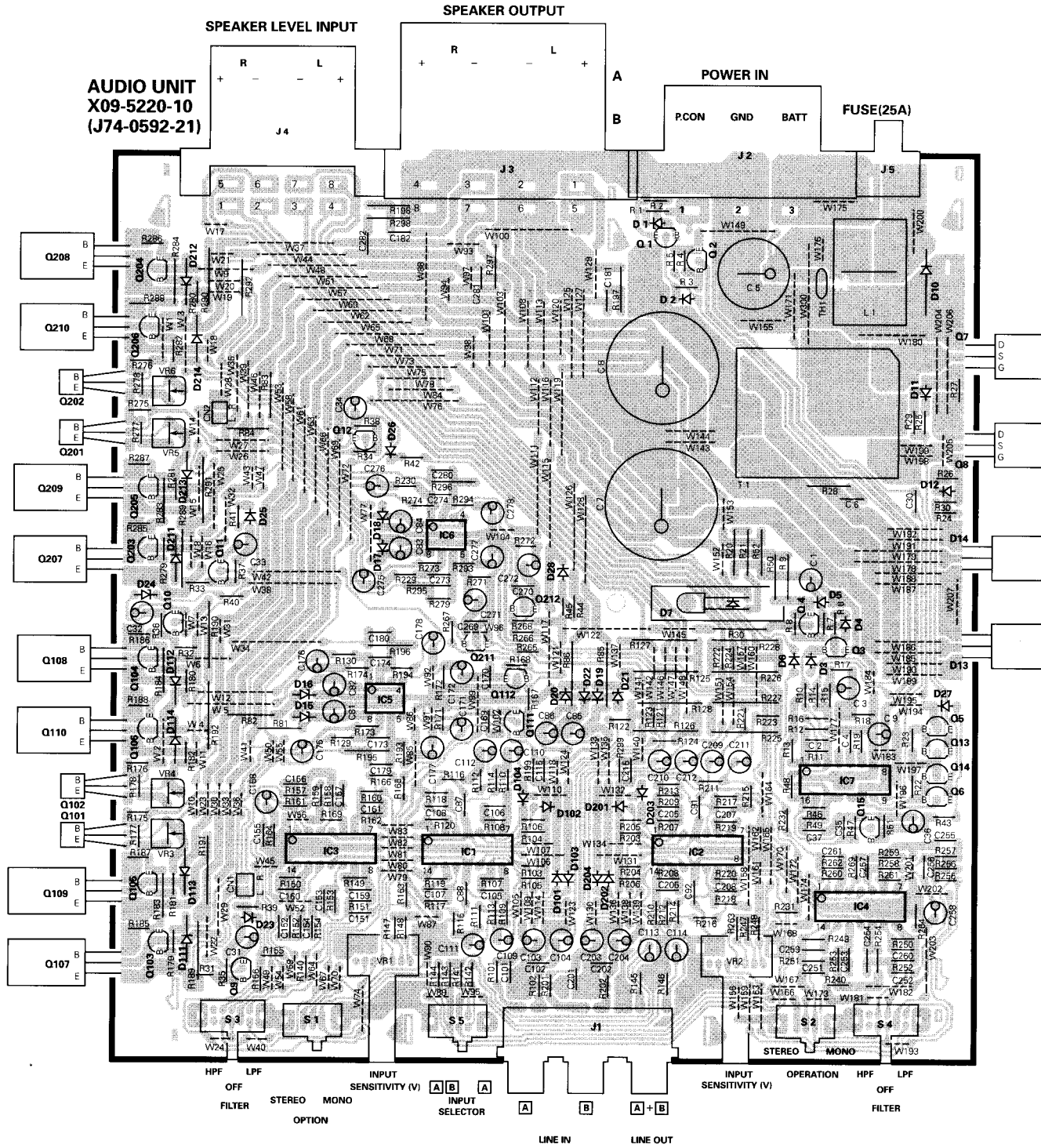

AUDIO UNIT (X09-5220-10)

2SA733(A)
2SA817A
2SC1627A
2SC945(A)

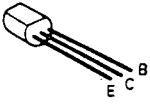

2SA1725*B
2SC4511*B



UPC4574C

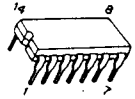

UPC494C

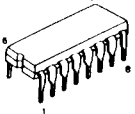

M5219P

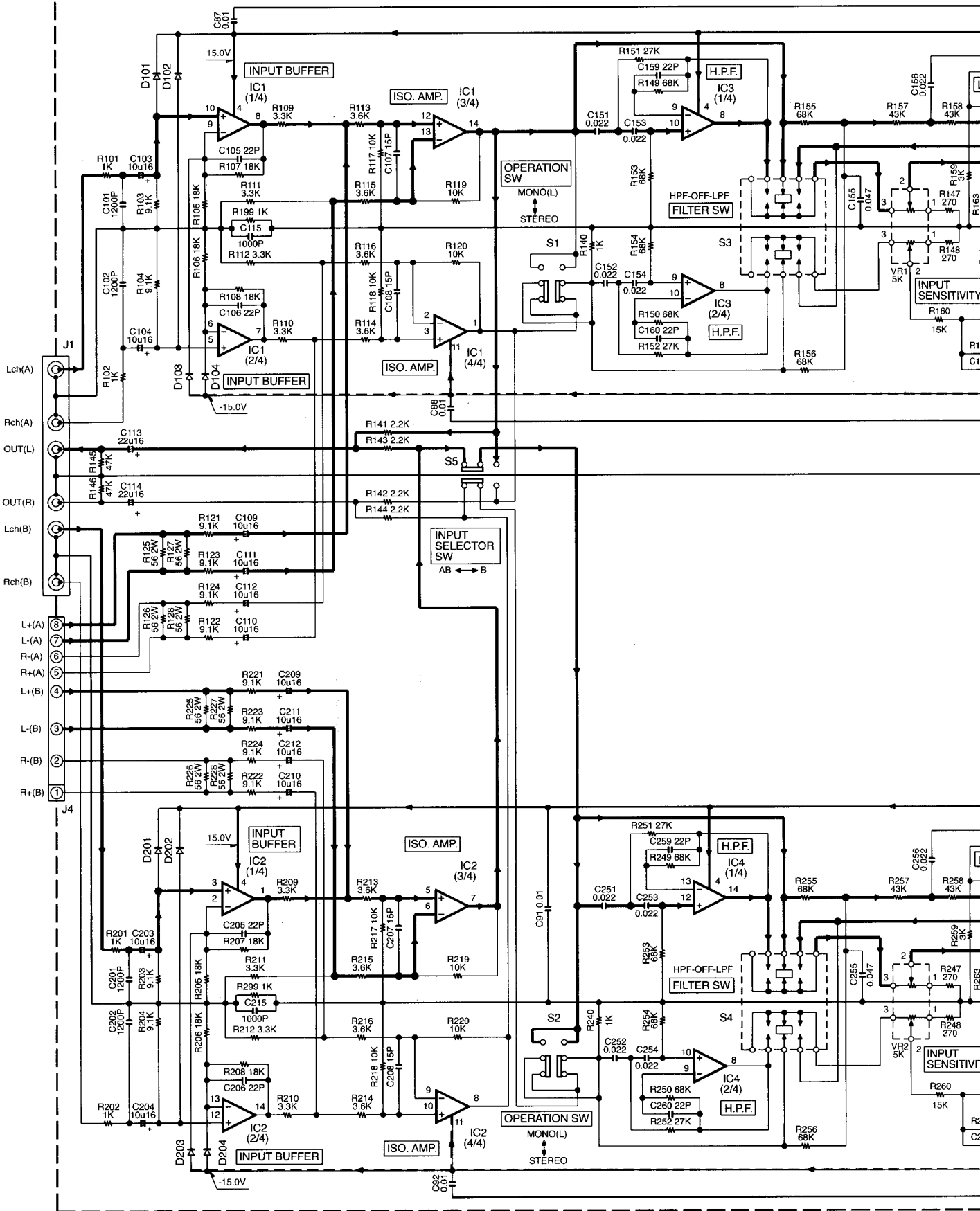
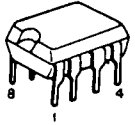

CAUTION: For continued safety, replace safety critical components only with manufacturer's recommended parts (refer to parts list). Δ indicates safety critical components. For continued protection against risk of fire, replace only with same type and rating fuse(s). To reduce the risk of electric shock, leakage-current or resistance measurements shall be carried out (exposed parts are acceptably insulated from the supply circuit) before the appliance is returned to the customer.

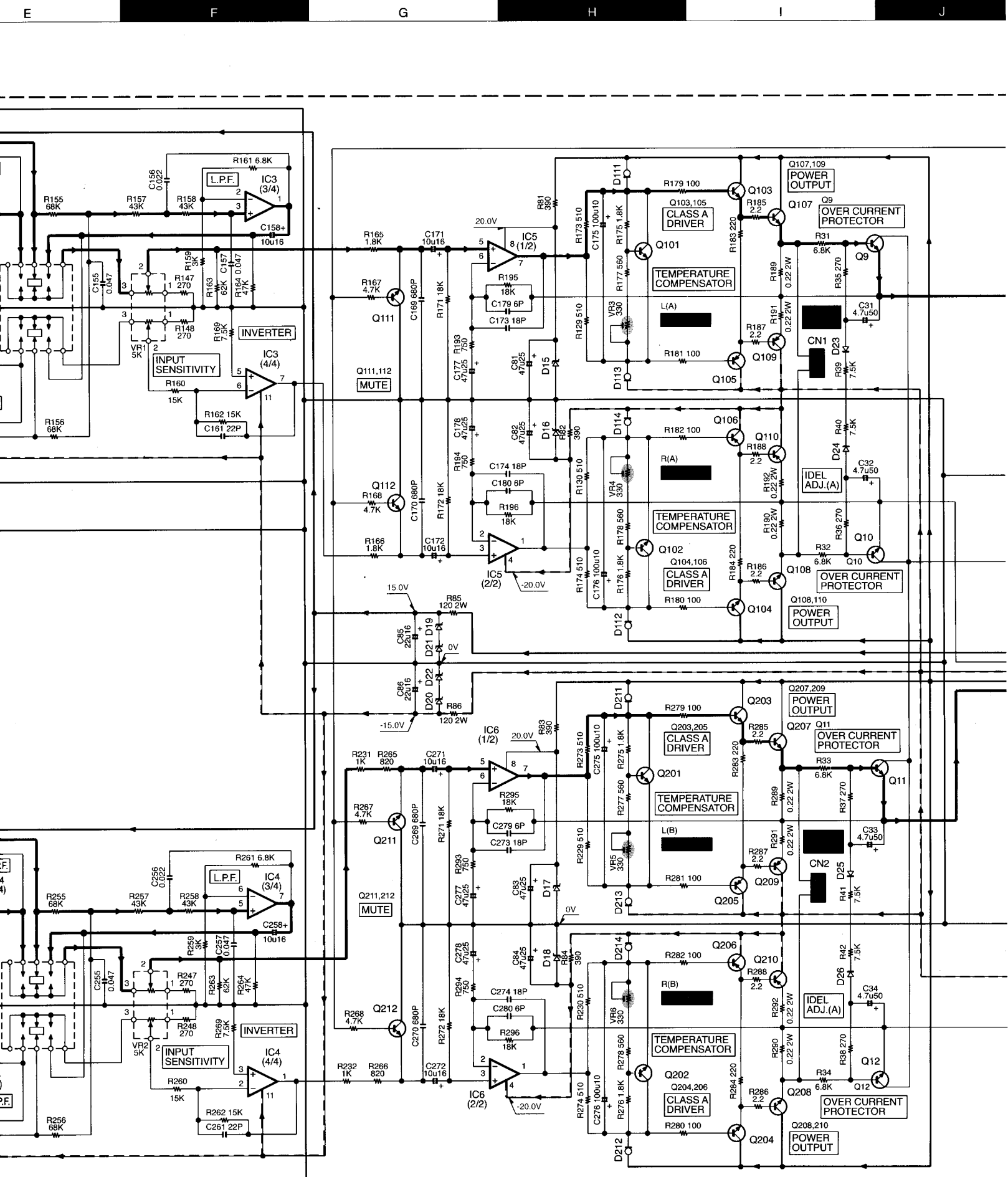

ended parts (refer to parts list). Δ indicate type and rating fuse(s). To reduce the risk of fire, use only components that are acceptably insulated from the sup-

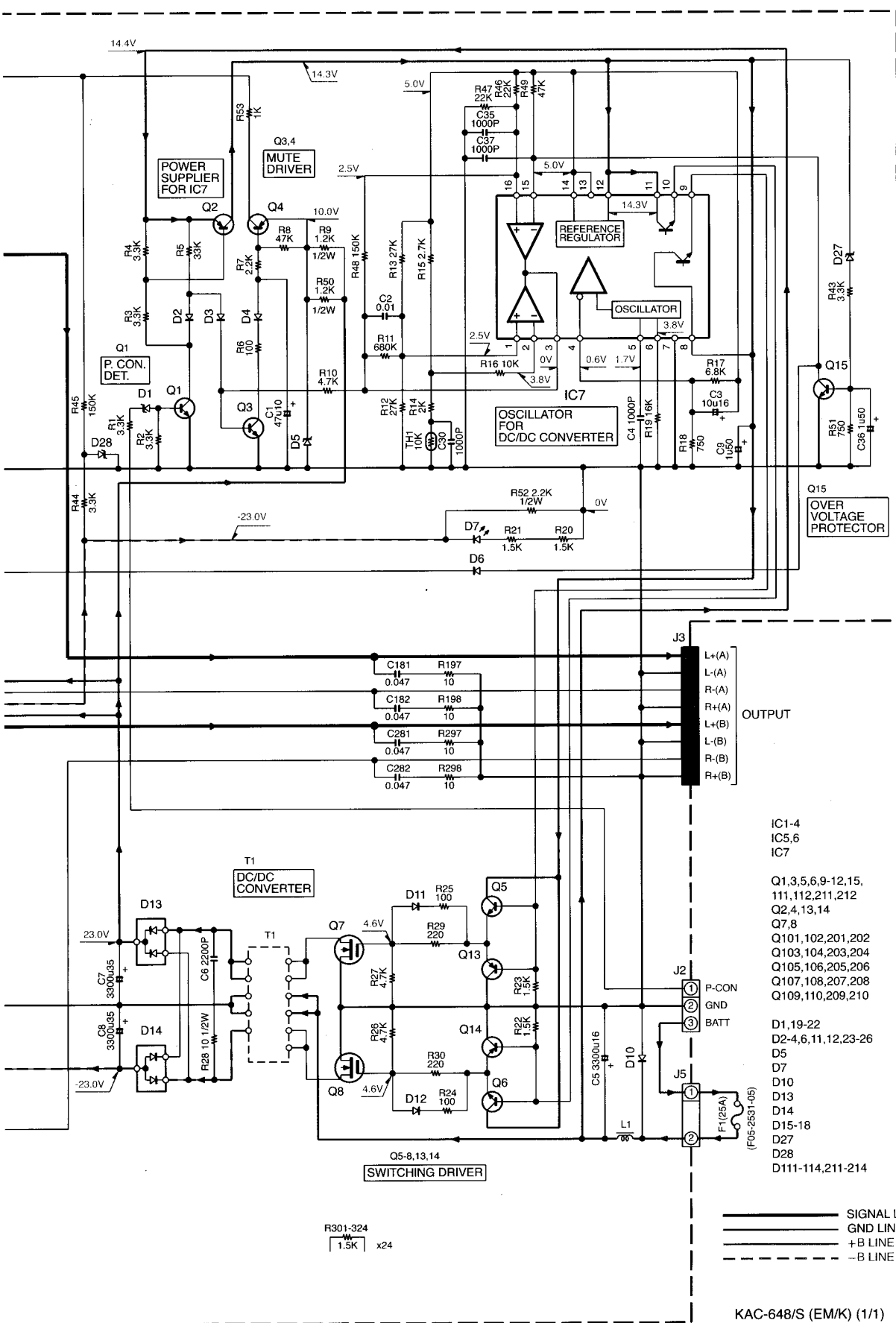

- IC1-4 : UPC4574C
- IC5,6 : M5219P
- IC7 : UPC494C
- Q1,3,5,6,9-12,15, 111,112,211,212 : 2SC945(A)(Q,P)
- Q2,4,13,14 : 2SA733(A)(Q,P)
- Q7,8 : MTAJ50N05HDLFK
- Q101,102,201,202 : 2SC945(A)(Q)
- Q103,104,203,204 : 2SC1627A
- Q105,106,205,206 : 2SA817A
- Q107,108,207,208 : 2SC4511 *B
- Q109,110,209,210 : 2SA1725 *B
- D1,19-22 : RD7.5JS(B)
- D2-4,6,11,12,23-26 : MA165
- D5 : RD10JS(B)
- D7 : B30-1460-05
- D10 : RM4ZLF-J1
- D13 : FMU22S *A
- D14 : FMU22R *A
- D15-18 : RD20JS(B)
- D27 : RD15JS(B)
- D28 : RD5.1JS(B)
- D111-114,211-214 : E-562

——— SIGNAL LINE
 - - - GND LINE
 ——— +B LINE
 - - - -B LINE

KAC-648/S (EM/K) (1/1)

KAC-648/S

EXPLODED VIEW

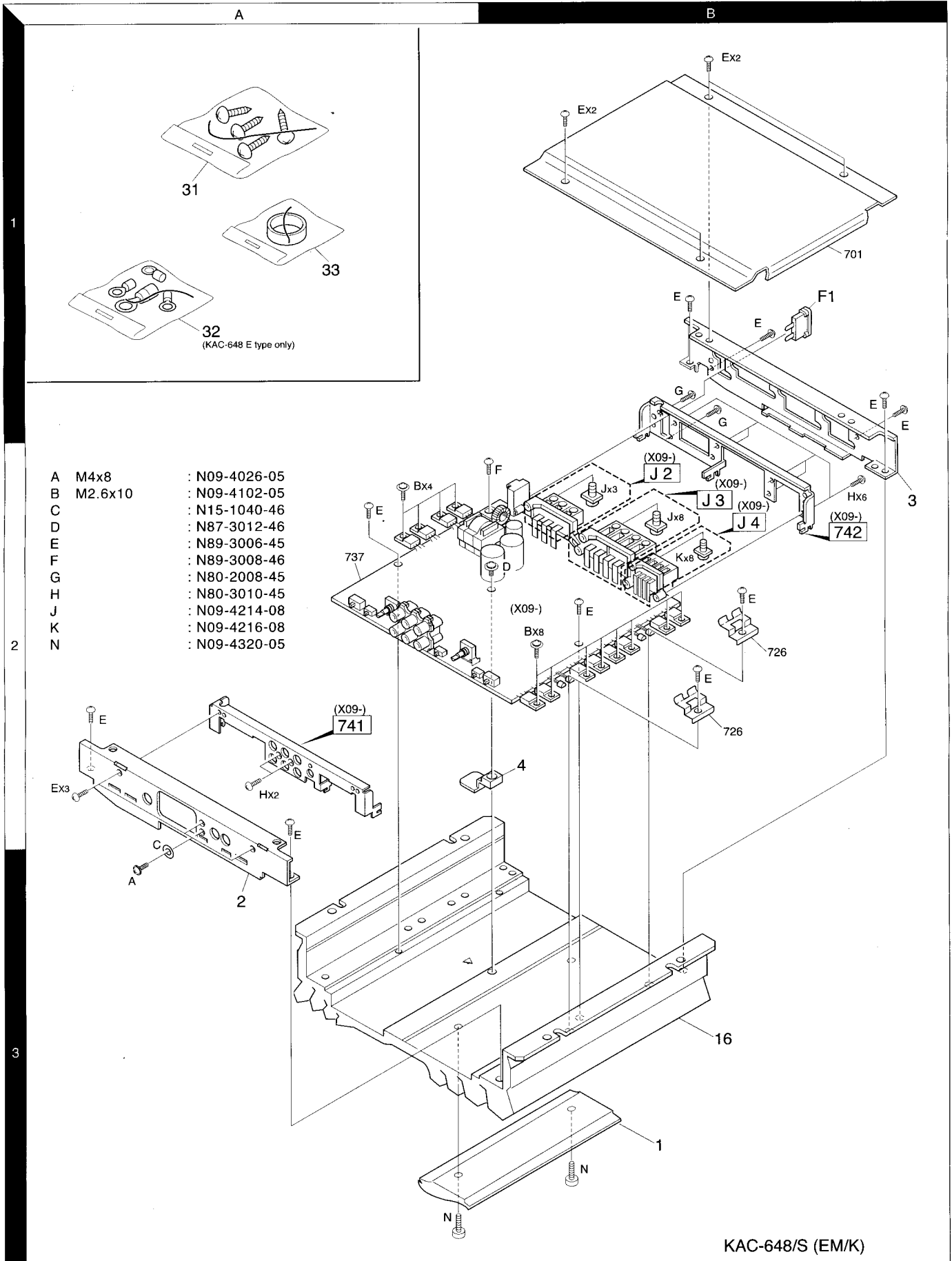

KAC-648/S (EM/K)

Parts with exploded numbers larger than 700 are not supplied.

PARTS LIST

* New Parts

Parts without **Part No.** are not supplied.

Les articles non mentionnes dans le **Parts No.** ne sont pas fournis.

Teile ohne **Parts No.** werden nicht geliefert.

(X09-5220-10)

Ref. No.	A d d	N e w	Parts No.	Description	Desti- nation
KAC-648/S					
1	3B	*	A21-3562-03	DRESSING PANEL	K
1	3B	*	A21-3570-03	DRESSING PANEL	E1M1
2	3A	*	A64-1732-02	FRONT PANEL	
3	2B	*	A84-0197-02	REAR PANEL	
4	2B	*	B19-1186-03	LIGHTING BOARD	
-			B46-0100-50	WARRANTY CARD	
-		*	B64-1363-00	INST. MANUAL (ENG,FRE,SPA)	K
-		*	B64-1364-00	INST. MANUAL (ENG,FRE,GER,DUT)	E1
-		*	B64-1364-00	INST. MANUAL (ITA,SPA,POR)	E1
-		*	B64-1365-00	INST. MANUAL (ENG,CHI)	M1
16	3B	*	F01-1597-01	HEAT SINK (TOP COVER)	
F1	1B		F05-2531-05	FUSE (25A BLADE TYPE)	
-		*	H10-4645-03	POLYSTYRENE FOAMED FIXTURE	
-			H25-0321-04	PROTECTION BAG (600X315X0.03)	
-			H25-0336-04	PROTECTION BAG (170X250X0.03)	
-		*	H54-1422-03	ITEM CARTON CASE (KAC-648S)	K
-		*	H54-1430-03	ITEM CARTON CASE (KAC-648)	E1M1
31	1A		N99-1587-05	SCREW SET	
A	2A		N09-4026-05	TAPPING SCREW (4X8,TP,S)	
B	2A		N09-4102-05	SEMS (MACHINE SCREW) (M2.6X10)	
C	2A		N15-1040-46	FLAT WASHER	
D	2B		N87-3012-46	BRAZIER HEAD TAPTITE SCREW	
E	1B		N89-3006-45	BINDING HEAD TAPTITE SCREW	
F	2B		N89-3008-46	BINDING HEAD TAPTITE SCREW	
N	3A	*	N09-4320-05	DRESSED SCREW (M4X10)	
△ 32	1A	*	W01-0798-05	LEAD TERMINAL SET	E1
33	1A		W01-0748-05	TERMINAL COVER SET	
AUDIO UNIT (X09-5220-10)					
D7			B30-1460-05	LED (RED)	
C1			CE04DW1A470M	ELECTRO 47UF 10WV	
C2			CK45FF1H103Z	CERAMIC 0.010UF Z	
C3			CE04DW1C100M	ELECTRO 10UF 16WV	
C4			CF92FV1H102J	MF-C 1000PF J	
C5			C90-2689-05	ELECTRO 3300UF 16WV	
C6			CF92FV1H222J	MF-C 2200PF J	
C7 ,8			C90-1616-05	ELECTRO 3300UF 35WV	
C9			CE04DW1H010M	ELECTRO 1.0UF 50WV	
C30			CK45FB1H102K	CERAMIC 1000PF K	
C31 -34			CE04DW1H4R7M	ELECTRO 4.7UF 50WV	
C35			CK45FB1H102K	CERAMIC 1000PF K	
C36			CE04DW1H010M	ELECTRO 1.0UF 50WV	
C37			CK45FB1H102K	CERAMIC 1000PF K	
C81 -84			CE04DW1E470M	ELECTRO 47UF 25WV	
C85 ,86			CE04DW1C220M	ELECTRO 22UF 16WV	
C87 ,88			CK45FF1H103Z	CERAMIC 0.010UF Z	
C91 ,92			CK45FF1H103Z	CERAMIC 0.010UF Z	
C101,102			CK45FB1H122K	CERAMIC 1200PF K	
C103,104			CE04DW1C100M	ELECTRO 10UF 16WV	
C105,106			CC45FSL1H220J	CERAMIC 22PF J	
C107,108			CC45FCH1H150J	CERAMIC 15PF J	

Ref. No.	A d d	N e w	Parts No.	Description	Desti- nation
C109-112			CE04DW1C100M	ELECTRO 10UF 16WV	
C113,114			CE04DW1C220M	ELECTRO 22UF 16WV	
C115			CF92FV1H102J	MF-C 1000PF J	
C151-154			CF92FV1H223J	MF-C 0.022UF J	
C155			CF92FV1H473J	MF-C 0.047UF J	
C156			CF92FV1H223J	MF-C 0.022UF J	
C157			CF92FV1H473J	MF-C 0.047UF J	
C158			CE04DW1C100M	ELECTRO 10UF 16WV	
C159-161			CC45FSL1H220J	CERAMIC 22PF J	
C169,170			CK45FB1H681K	CERAMIC 680PF K	
C171,172			CE04DW1C100M	ELECTRO 10UF 16WV	
C173,174			CC45FSL1H180J	CERAMIC 18PF J	
C175,176			CE04DW1A101M	ELECTRO 100UF 10WV	
C177,178			CE04DW1E470M	ELECTRO 47UF 25WV	
C179,180			CC45FSL1H060D	CERAMIC 6.0PF D	
C181,182			CF92FV1H473J	MF-C 0.047UF J	
C201,202			CK45FB1H122K	CERAMIC 1200PF K	
C203,204			CE04DW1C100M	ELECTRO 10UF 16WV	
C205,206			CC45FSL1H220J	CERAMIC 22PF J	
C207,208			CC45FCH1H150J	CERAMIC 15PF J	
C209-212			CE04DW1C100M	ELECTRO 10UF 16WV	
C215			CF92FV1H102J	MF-C 1000PF J	
C251-254			CF92FV1H223J	MF-C 0.022UF J	
C255			CF92FV1H473J	MF-C 0.047UF J	
C256			CF92FV1H223J	MF-C 0.022UF J	
C257			CF92FV1H473J	MF-C 0.047UF J	
C258			CE04DW1C100M	ELECTRO 10UF 16WV	
C259-261			CC45FSL1H220J	CERAMIC 22PF J	
C269,270			CK45FB1H681K	CERAMIC 680PF K	
C271,272			CE04DW1C100M	ELECTRO 10UF 16WV	
C273,274			CC45FSL1H180J	CERAMIC 18PF J	
C275,276			CE04DW1A101M	ELECTRO 100UF 10WV	
C277,278			CE04DW1E470M	ELECTRO 47UF 25WV	
C279,280			CC45FSL1H060D	CERAMIC 6.0PF D	
C281,282			CF92FV1H473J	MF-C 0.047UF J	
CN1 ,2			E40-3640-05	PIN ASSY	
J1		*	E63-0846-05	PHONO JACK	
△ J2	2B		E70-0807-05	SCREW TERMINAL BOARD	
J3	2B		E70-0819-05	SCREW TERMINAL BOARD	
J4	2B		E70-0821-05	SCREW TERMINAL BOARD	
△ J5			J13-0602-05	FUSE HOLDER	
L1			L33-1032-05	CHOKE COIL	
T1			L19-0556-05	DC/DC CONVERTER	
G	1B		N80-2008-45	PAN HEAD TAPTITE SCREW	
H	2B		N80-3010-45	PAN HEAD TAPTITE SCREW	
J	2B		N09-4214-08	SEMS	
K	2B		N09-4216-08	SEMS	
R1 -4			RD14BB2C332J	RD 3.3K J 1/6W	
R5			RD14BB2C333J	RD 33K J 1/6W	
R6			RD14BB2C101J	RD 100 J 1/6W	
R7			RD14BB2C222J	RD 2.2K J 1/6W	
R8			RD14BB2C473J	RD 47K J 1/6W	
R9			RD14DB2H122J	SMALL-RD 1.2K J 1/2W	

E : Europe K : North America M : Other Areas
W : Without Europe

E1 : KAC-648
K : KAC-648S
M1 : KAC-648

△ indicates safety critical components.

PARTS LIST

* New Parts

Parts without **Part No.** are not supplied.

Les articles non mentionnes dans le **Parts No.** ne sont pas fournis.

Teile ohne **Parts No.** werden nicht geliefert.

(X09-5220-10)

Ref. No.	A d d	N e w	Parts No.	Description	Desti- nation	Ref. No.	A d d	N e w	Parts No.	Description	Desti- nation
R10			RD14BB2C472J	RD 4.7K J 1/6W		R171,172			RD14BB2C183J	RD 18K J 1/6W	
R11			RD14BB2C684J	RD 680K J 1/6W		R173,174			RD14BB2C511J	RD 510 J 1/6W	
R12,13			RD14BB2C273J	RD 27K J 1/6W		R175,176			RD14BB2C182J	RD 1.8K J 1/6W	
R14			RD14BB2C202J	RD 2.0K J 1/6W		R177,178			RD14BB2C561J	RD 560 J 1/6W	
R15			RD14BB2C272J	RD 2.7K J 1/6W		R179-182			RD14BB2C101J	RD 100 J 1/6W	
R16			RD14BB2C103J	RD 10K J 1/6W		R183,184			RD14BB2E221J	RD 220 J 1/4W	
R17			RD14BB2C682J	RD 6.8K J 1/6W		R185-188			RD14BB2C2R2J	RD 2.2 J 1/6W	
R18			RD14BB2C751J	RD 750 J 1/6W		R189-192			RS14KB3DR22J	FL-PROOF RS 0.22 J 2W	
R19			RD14BB2C163J	RD 16K J 1/6W		R193,194			RD14BB2C751J	RD 750 J 1/6W	
R20,21			RD14BB2E152J	RD 1.5K J 1/4W		R195,196			RD14BB2E183J	RD 18K J 1/4W	
R22,23			RD14BB2C152J	RD 1.5K J 1/6W		R197,198			RD14BB2E100J	RD 10 J 1/4W	
R24,25			RD14BB2C101J	RD 100 J 1/6W		R199			RD14BB2C102J	RD 1.0K J 1/6W	
R26,27			RD14BB2C472J	RD 4.7K J 1/6W		R201,202			RD14BB2C102J	RD 1.0K J 1/6W	
R28			RD14DB2H100J	SMALL-RD 10 J 1/2W		R203,204			RD14BB2C912J	RD 9.1K J 1/6W	
R29,30			RD14BB2C221J	RD 220 J 1/6W		R205-208			RD14BB2C183J	RD 18K J 1/6W	
R31-34			RD14BB2C682J	RD 6.8K J 1/6W		R209-212			RD14BB2C332J	RD 3.3K J 1/6W	
R35-38			RD14BB2C271J	RD 270 J 1/6W		R213-216			RD14BB2C362J	RD 3.6K J 1/6W	
R39-42			RD14BB2C752J	RD 7.5K J 1/6W		R217-220			RD14BB2C103J	RD 10K J 1/6W	
R43,44			RD14BB2C332J	RD 3.3K J 1/6W		R221-224			RD14BB2C912J	RD 9.1K J 1/6W	
R45			RD14BB2C154J	RD 150K J 1/6W		R225-228			RS14KB3D560J	FL-PROOF RS 56 J 2W	
R46,47			RD14BB2C223J	RD 22K J 1/6W		R229,230			RD14BB2C511J	RD 510 J 1/6W	
R48			RD14BB2C154J	RD 150K J 1/6W		R231,232			RD14BB2C102J	RD 1.0K J 1/6W	
R49			RD14BB2C473J	RD 47K J 1/6W		R240			RD14BB2C102J	RD 1.0K J 1/6W	
R50			RD14DB2H122J	SMALL-RD 1.2K J 1/2W		R247,248			RD14BB2C271J	RD 270 J 1/6W	
R51			RD14BB2C751J	RD 750 J 1/6W		R249,250			RD14BB2C683J	RD 68K J 1/6W	
R52			RD14DB2H222J	SMALL-RD 2.2K J 1/2W		R251,252			RD14BB2C273J	RD 27K J 1/6W	
R53			RD14BB2C102J	RD 1.0K J 1/6W		R253-256			RD14BB2C683J	RD 68K J 1/6W	
R81-84			RD14BB2E391J	RD 390 J 1/4W		R257,258			RD14BB2C433J	RD 43K J 1/6W	
R85,86			RS14KB3D121J	FL-PROOF RS 120 J 2W		R259			RD14BB2C302J	RD 3.0K J 1/6W	
R101,102			RD14BB2C102J	RD 1.0K J 1/6W		R260			RD14BB2C153J	RD 15K J 1/6W	
R103,104			RD14BB2C912J	RD 9.1K J 1/6W		R261			RD14BB2C682J	RD 6.8K J 1/6W	
R105-108			RD14BB2C183J	RD 18K J 1/6W		R262			RD14BB2C153J	RD 15K J 1/6W	
R109-112			RD14BB2C332J	RD 3.3K J 1/6W		R263			RD14BB2C623J	RD 62K J 1/6W	
R113-116			RD14BB2C362J	RD 3.6K J 1/6W		R264			RD14BB2C473J	RD 47K J 1/6W	
R117-120			RD14BB2C103J	RD 10K J 1/6W		R265,266			RD14BB2C821J	RD 820 J 1/6W	
R121-124			RD14BB2C912J	RD 9.1K J 1/6W		R267,268			RD14BB2C472J	RD 4.7K J 1/6W	
R125-128			RS14KB3D560J	FL-PROOF RS 56 J 2W		R269			RD14BB2C752J	RD 7.5K J 1/6W	
R129,130			RD14BB2C511J	RD 510 J 1/6W		R271,272			RD14BB2C183J	RD 18K J 1/6W	
R140			RD14BB2C102J	RD 1.0K J 1/6W		R273,274			RD14BB2C511J	RD 510 J 1/6W	
R141-144			RD14BB2C222J	RD 2.2K J 1/6W		R275,276			RD14BB2C182J	RD 1.8K J 1/6W	
R145,146			RD14BB2C473J	RD 47K J 1/6W		R277,278			RD14BB2C561J	RD 560 J 1/6W	
R147,148			RD14BB2C271J	RD 270 J 1/6W		R279-282			RD14BB2C101J	RD 100 J 1/6W	
R149,150			RD14BB2C683J	RD 68K J 1/6W		R283,284			RD14BB2E221J	RD 220 J 1/4W	
R151,152			RD14BB2C273J	RD 27K J 1/6W		R285-288			RD14BB2C2R2J	RD 2.2 J 1/6W	
R153-156			RD14BB2C683J	RD 68K J 1/6W		R289-292			RS14KB3DR22J	FL-PROOF RS 0.22 J 2W	
R157,158			RD14BB2C433J	RD 43K J 1/6W		R293,294			RD14BB2C751J	RD 750 J 1/6W	
R159			RD14BB2C302J	RD 3.0K J 1/6W		R295,296			RD14BB2E183J	RD 18K J 1/4W	
R160			RD14BB2C153J	RD 15K J 1/6W		R297,298			RD14BB2E100J	RD 10 J 1/4W	
R161			RD14BB2C682J	RD 6.8K J 1/6W		R299			RD14BB2C102J	RD 1.0K J 1/6W	
R162			RD14BB2C153J	RD 15K J 1/6W		R301-324			RD14BB2E152J	RD 1.5K J 1/4W	
R163			RD14BB2C623J	RD 62K J 1/6W		VR1,2			R31-0209-05	VARIABLE RESISTOR (5K)	
R164			RD14BB2C473J	RD 47K J 1/6W		VR3-6			R12-0606-05	TRIMMING POT. (330)	
R165,166			RD14BB2C182J	RD 1.8K J 1/6W		S1,2			S62-0842-05	SLIDE SWITCH	
R167,168			RD14BB2C472J	RD 4.7K J 1/6W		S3,4			S31-2630-05	SLIDE SWITCH	
R169			RD14BB2C752J	RD 7.5K J 1/6W							

E : Europe K : North America M : Other Areas
W : Without Europe

E1 : KAC-648
K : KAC-648S
M1 : KAC-648

▲ indicates safety critical components.

PARTS LIST

*** New Parts**

Parts without **Part No.** are not supplied.

Les articles non mentionnes dans le **Parts No.** ne sont pas fournis.

Teile ohne **Parts No.** werden nicht geliefert.

(X09-5220-10)

Ref. No.	A d d	N e w	Parts No.	Description	Desti- nation	Ref. No.	A d d	N e w	Parts No.	Description	Desti- nation
S5			S62-0842-05	SLIDE SWITCH							
D1			RD7.5JS(B)	ZENER DIODE							
D2 -4			MA165	DIODE							
D2 -4			1SS176	DIODE							
D5			RD10JS(B)	ZENER DIODE							
D6			MA165	DIODE							
D6			1SS176	DIODE							
D10			RM4ZLF-J1	DIODE							
D11 ,12			MA165	DIODE							
D13			FMU22S*A	DIODE							
D14			FMU22R*A	DIODE							
D15 -18			RD20JS(B)	ZENER DIODE							
D19 -22			RD7.5JS(B)	ZENER DIODE							
D23 -26			MA165	DIODE							
D23 -26			1SS176	DIODE							
D27			RD15JS(B)	ZENER DIODE							
D28			RD5.1JS(B)	ZENER DIODE							
D101-104			MA165	DIODE							
D111-114			E-562	CONSTANT CURRENT DIODE							
D201-204			MA165	DIODE							
D211-214			E-562	CONSTANT CURRENT DIODE							
IC1 -4			UPC4574C	IC(OP AMP X4)							
IC5 ,6			M5219P	IC(OP AMP X2)							
IC7			UPC494C	IC(SWITCHING REGULATOR)							
Q1			2SC945(A)(Q,P)	TRANSISTOR							
Q2			2SA733(A)(Q,P)	TRANSISTOR							
Q3			2SC945(A)(Q,P)	TRANSISTOR							
Q4			2SA733(A)(Q,P)	TRANSISTOR							
Q5 ,6			2SC945(A)(Q,P)	TRANSISTOR							
Q7 ,8			MTAJ50N05HDLFK	FET							
Q9 -12			2SC945(A)(Q,P)	TRANSISTOR							
Q13 ,14			2SA733(A)(Q,P)	TRANSISTOR							
Q15			2SC945(A)(Q,P)	TRANSISTOR							
Q101,102			2SC945(A)(Q)	TRANSISTOR							
Q103,104			2SC1627A	TRANSISTOR							
Q105,106			2SA817A	TRANSISTOR							
Q107,108			2SC4511*B	TRANSISTOR							
Q109,110			2SA1725*B	TRANSISTOR							
Q111,112			2SC945(A)(Q,P)	TRANSISTOR							
Q201,202			2SC945(A)(Q)	TRANSISTOR							
Q203,204			2SC1627A	TRANSISTOR							
Q205,206			2SA817A	TRANSISTOR							
Q207,208			2SC4511*B	TRANSISTOR							
Q209,210			2SA1725*B	TRANSISTOR							
Q211,212			2SC945(A)(Q,P)	TRANSISTOR							
TH1			ERT-D2ZHL103S	THERMISTOR							

E : Europe **K** : North America **M** : Other Areas
W : Without Europe

E1 : KAC-648
K : KAC-648S
M1 : KAC-648

 indicates safety critical components.

KAC-648/S

SPECIFICATIONS

Audio Section

Max Power Output (4 Ω)

4-channel Mode	50W x 4
3-channel Mode	(50W x 2) + (140W x 1)
2-channel Mode	140W x 2

Rated Power Output (4 Ω)

4-channel Mode	25W x 4
(20Hz-20KHz, less than 0.08% THD)	
(DIN45324, +B=14.4V)	
3-channel Mode (1KHz)	(25W x 2 at 0.08% THD)+
	(70W x 1 at 0.8% THD)
2-channel Mode (1KHz, 0.8% THD)	70W x 2

Rated Power Output (2 Ω)

4-channel Mode (1KHz, 0.8% THD)	35W x 4
Frequency Response (+0, -1dB)	10Hz - 45KHz
Signal to Noise Ratio	100dB
Sensitivity (MAX) (rated output)	0.2V
Sensitivity (MIN) (rated output)	4.0V
Input Impedance	10K Ω
Low Pass Filter (12dB/oct.)	80Hz
High Pass Filter (12dB/oct.)	150Hz

General

Operating Voltage (11V-16V allowable)	14.4V
Current Consumption (1KHz, 10% THD)	22A
Dimensions (Width x Height x Depth)	260mm x 56.5mm x 209mm
Weight	3.0Kg

KENWOOD follows a policy of continuous advancements in development. For this reason specifications may be changed without notice.

KENWOOD CORPORATION

14-6, Dogenzaka 1-chome, Shibuya-ku, Tokyo, 150-8501 Japan

KENWOOD SERVICE CORPORATION

P.O. Box 22745, 2201 East Dominguez Street,
Long Beach, CA90801-5745, U.S.A.

KENWOOD ELECTRONICS CANADA INC.

6070 Kestrel Road, Mississauga, Ontario, Canada L5T 1S8

KENWOOD ELECTRONICS LATIN AMERICA S.A.

P.O. Box 55-2791, Piso 6, Plaza Chase, Cl. 47 y,
Aquilino de la Guardia, Panama, Republic of Panama

KENWOOD ELECTRONICS BRASIL LTDA.

Av. Moema, 170-17", Andar-Cobertura "B",
Ed. Maximum Service Center, 04077-020 Moema,
São Paulo-SP-Brasil

KENWOOD ELECTRONICS UK LIMITED

Kenwood House, Dwight Road, Watford,
Herts, WD1 8EB, United Kingdom

KENWOOD ELECTRONICS DEUTSCHLAND GMBH

Rembrücker Str. 15, 63150 Heusenstamm, Germany

KENWOOD ELECTRONICS FRANCE S.A.

13, Boulevard Ney, 75018 Paris, France

KENWOOD ELECTRONICS BELGIUM N.V.

Mechelsesteenweg 418, B-1930 Zaventem, Belgium

KENWOOD ELECTRONICS ITALIA S.p.A.

Via G. Sirtori 7/9, 20129 Milano, Italy

KENWOOD IBÉRICA S.A.

Bolivia, 239-08020 Barcelona, Spain

KENWOOD ELECTRONICS AUSTRALIA PTY. LTD.

(A.C.N. 001 499 074)
8 Figtree Drive, Australia Centre, Homebush, N.S.W. 2140, Australia

KENWOOD & LEE ELECTRONICS LTD.

Unit 3712-3724, Level 37, Tower 1, Metroplaza,
223 Hing Fong Road, Kwai Fong, N.T., Hong Kong

KENWOOD ELECTRONICS GULF FZE

P.O.Box 61318, Jebel Ali, Dubai, U.A.E.

KENWOOD ELECTRONICS (THAILAND) CO., LTD.

2019 New Pechburi Road, Bangkapi, Huaykwang,
Bangkok, 10320 Thailand

KENWOOD ELECTRONICS SINGAPORE PTE LTD.

1 Genting Lane, #07-00, Kenwood Building, Singapore 349544

KENWOOD ELECTRONICS (MALAYSIA) SDN BHD

#4.01 Level 4, Wisma Academy Lot 4A, Jalan 19/1,
46300 Petaling Jaya, Selangor Darul Ehsan, Malaysia